

GRADE 6

CAPS ATP
ALIGNED

TERM 3

TEST BUNDLE

PREVIEW



Grade 6 English FAL Term 3 Test I

QUESTION 1: READING COMPREHENSION

1. Read the passage below and answer the questions that follow.



Sourdough Bread

Sourdough bread is a type of bread made by the fermentation of dough using naturally occurring lactobacilli and yeast. Unlike other breads, which use commercial yeast, sourdough relies on a "starter" – a mixture of flour and water that ferments over time. This starter is what gives sourdough its unique tangy flavour and chewy texture.

The history of sourdough bread dates back thousands of years, with evidence suggesting it was first made in ancient Egypt. The method spread throughout Europe and became especially popular during the Gold Rush in San Francisco, where it was a staple for miners.

Making sourdough bread is both an art and a science. The process begins with the creation of the starter, which can take several days to develop. Once the starter is ready, it is mixed with more flour and water to make the dough. This dough then needs to rise, which can take several hours to overnight. After rising, the dough is shaped into loaves and baked.

The benefits of sourdough bread extend beyond its taste. The fermentation process breaks down gluten, making it easier to digest for some people. Additionally, sourdough has a lower glycemic index than other breads, meaning it causes a slower rise in blood sugar levels.

Sourdough bread requires patience and practice, but many bakers find the effort worthwhile. The result is a delicious, nutritious bread that is deeply rooted in history and tradition.

1.1. What is sourdough bread? (2)

1.2. How is sourdough bread different from other breads? (2)

2.5. Rewrite this sentence in the present tense: (1)

The children wrote exams in September.

2.6. Rewrite this sentence into the past tense: (1)

I will do my best in this exam.

2.7. Add an adverb to make this sentence interesting. (1)

The horse jumped _____ over the branch.

2.8. Complete the table by filling in the missing degrees of comparison. (2)

-----	hotter	-----
-------	--------	-------

2.9. Underline the adjectives in these sentences: (2)

a) The little girl was wearing a red and pink dress.

b) The tiny, brown snake was laying in the sun.

2.10. What is the collective noun for sheep? (1)

many bakers consider making sourdough bread worthwhile despite the tired? (2)

synonym in the text for the word 'repetition'

[20]

QUESTION 2: LANGUAGE STRUCTURES AND CONVENTIONS

Answer the following questions.

2.1. Choose the correct punctuation to the following sentence: (1)

The bakery is called eatmore bakery and it is located in durban

2.2. Circle the pronouns in these sentences: (2)

a) The girl left her jersey on the chair when she went to the bathroom.

b) My friend came to our house, but we had gone to the shops.

2.3. Write the plural form of each of these words: (4)

a) Bus _____

b) Apple _____

c) Bunch _____

d) Baby _____

2.4. Use words from the box to join the following sentences. (2)

and because so that but until while

a) I did not eat the pizza. I was not hungry.

b) She played games on her phone. She waited for the bus.

speech: (1)

irect speech: (1)

entence: (1)

[20]

GRAND TOTAL: 40 MARKS

inds

5

- Reading Comprehension (20)
- Language structures and conventions (20) (Synonyms, punctuation, pronouns, plurals, conjunctions, present tense, past tense, adverbs, adjectives, collective nouns, direct speech & indirect speech, gerunds)

Test Total: 40
Number of pages: 7



Grade 6 English HL Term 3 Test I

QUESTION 1: READING COMPREHENSION (20 MARKS)

1. Read the legend below and answer the questions that follow.

The Legend of the Rain Queen

Once upon a time, in the lush lands of Limpopo, there lived a powerful and wise queen known as Modjadji, the Rain Queen. According to the legend, Queen Modjadji had the magical ability to control the rain. Her people, the Balobedu tribe, revered her for this gift, as their livelihood depended on the seasonal rains to nourish their crops and fill their rivers.



It was said that Queen Modjadji inherited her powers from her ancestors, who had passed down the secrets of rainmaking through generations. The Rain Queen would perform sacred rituals and communicate with the spirits of nature to bring rain to her people. She lived in a secluded palace surrounded by beautiful gardens, where she cultivated rare plants and herbs used in her ceremonies.

One year, there was a terrible drought that threatened the land. The rivers dried up, the crops withered, and the people were desperate. The Balobedu turned to their queen for help. Queen Modjadji, understanding the gravity of the situation, retreated to her sacred grove to perform the most powerful rainmaking ritual known to her.

For days, she fasted and prayed, dancing under the ancient baobab trees, and chanting incantations. Her dedication and connection to the spiritual world were so profound that the skies began to darken, and thunder rumbled in the distance. Soon, rain clouds gathered, and a mighty storm broke out, pouring life-giving water over the parched land.

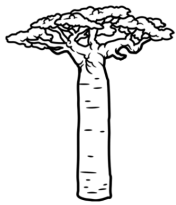

The people rejoiced, their faith in their queen reaffirmed. The rivers flowed again, and the fields turned green with abundance. Queen Modjadji's legend grew even stronger, and she continued to be a beacon of hope and prosperity for her people.

To this day, the story of Queen Modjadji is told across South Africa, a testament to the enduring power of nature and the sacred bond between a leader and her people.

1.1. Who was Queen Modjadji and what special ability did she possess? (2)

©DesigningMinds

2

QUESTION 2: LANGUAGE (20 MARKS)

2. Answer the following language questions.

2.1. Add suitable conjunctions to change these simple sentences into complex sentences.

a) I went to the shop. I wanted chips.



(1)

b) I went to the shop to buy sweets. I realised I had no money.

(1)

2.2. Change this indirect speech into direct speech.

a) Sameera asked if Miss Smith was at school.



(1)

b) Miss Smith yelled that Levi should bring his bag immediately.

(1)

2.3. Add two adjectives to the sentence below.

(2)

What can we learn about leadership from the story of Queen Modjadji? (2)

Do you think the legend of Queen Modjadji could inspire people today? Why or why not? (2)

Tick the correct answer. What is the mood of the story? (1)

- sad and gloomy
 angry and vengeful
 reverent and hopeful
 confused and chaotic

Tick the correct answer. "The skies began to darken" in paragraph 4, is an example of (1)

- a) hyperbole
 b) personification
 c) simile
 d) alliteration

1.13. Underline the adjective in the following sentence. (1)

"Soon, rain clouds gathered, and a mighty storm broke out."

in each sentence. (2)

ii).

pronoun. (2)

Mark's and Tom's homework.

Mark's and Tom's exam today."

5

• Reading Comprehension (20)

• Language structures and conventions (20)

(Synonyms & antonyms, adjectives, conjunctions, direct speech, auxiliary verbs, homophones, pronouns, figures of speech, comparative & superlative, gerund, passive voice, contractions, verb clause, sentence types)



©DesigningMinds

4

Test Total: 40

Number of pages: 8

Dm

Grade 6 English HL Term 3 Test 2

QUESTION 1: READING COMPREHENSION

1. Read the text below and answer the questions that follow.

Why the Tortoise Has a Cracked Shell

Long ago, when animals could talk, the birds decided to have a great feast in the sky. Tortoise, who loved food more than anything, wanted to join them. But he could not fly. He came up with a clever idea. He asked each bird to lend him a feather so he could make wings for himself. The birds agreed, and soon Tortoise was flying high in the sky with his new wings.



Before the feast began, Tortoise told the birds, "We must all take new names for this special event. I will call myself 'All of You', because the food is for all of you." The birds did not think much of it and agreed.

When the feast was served, the birds asked the host, "Who is the food for?" The host replied, "It is for all of you." But Tortoise stood up quickly and said, "That is me! I am All of You." Then he ate all the food by himself.

The birds were very angry. They took back their feathers and left Tortoise alone in the sky. With no wings to fly, he fell to the ground. His shell cracked into many pieces. He survived, but his shell has never looked the same again.



That is why, to this day, the tortoise has a cracked shell.

1.1. Why did the tortoise want to go to the feast? (1)

1.2. How did the tortoise manage to fly? (1)

1.3. What type of story is this? (1)

- a) A biography
 b) A fable
 c) A news report
 d) A fairy tale

©DesigningMinds

2

QUESTION 3: LANGUAGE

3. Answer the following language questions.

3.1. Underline the adjective/s in the sentence below: (1)

The loud music from the busy street kept us awake all night.

3.2. Underline the gerund in the sentence: (1)

Reading helps to improve your vocabulary.

3.3. Rewrite the following sentence in passive voice: (1)

The chef baked a delicious cake.



3.4. Rewrite the sentence in the negative form: (1)

She likes playing soccer.

3.5. Underline the adverb in the sentence below and state the type (manner, time, or place): (1)

We will visit Granny tomorrow.

3.6. Underline the subject in the sentence below: (1)

Is said they were angry.

ound, or complex: (3)

ving: (1)

s to complete the sentence: (2)

QUESTION 2: CREATIVE WRITING

ine you are Naledi, and you are writing a diary entry about the day you got lost on a school trip. Describe how you got separated from the group, how you felt while re lost, and how you eventually found your way back.

te 2–3 paragraphs (at least 100–120 words).

the first person ("I") and past tense.

adjectives, adverbs, and feelings to make your writing more interesting.

your diary entry a date and greeting, like a real diary.

101

©DesigningMinds

4

- Reading Comprehension (15)
- Creative Writing (10)
- Language structures & conventions (15)

(Adjectives, gerund, passive voice, negative form, adverbs, nouns, simple, compound & complex sentences, roots, verb clause, prefixes & suffixes, indirect speech)

Test Total: 40
 Number of pages: 8



Grade 6 Afrikaans FAL Term 3 Test 1

VRAAG 1: LITERÊRE / NIE -LITERÊRE TEKS

1. Lees die volgende storie deur en beantwoord die vrae wat volg.

Die Avonture van Karla en haar Hond

Karla was 'n avontuurlustige meisie wat daarvan gehou het om nuwe plekke te verken. Sy het altyd haar hond, Bruno, saamgeneem op haar avonture. Een dag het Karla en Bruno besluit om na die ou bos naby hulle huis te gaan.



Hulle het vroeg die oggend begin stap. Die bos was vol pragtige bome en kleurvolle blomme. Terwyl hulle stap, het hulle 'n ou gebou opgemerk wat deur die bome verberg was. Karla het besluit om nader te gaan om te kyk.

Toe hulle by die gebou kom, het Karla en Bruno gesien dat dit 'n verlate huis was. Die deure was toegegroe met klimop, en die vensters was stowwerig. Karla het 'n bietjie bang gevoel, maar Bruno het geblaf en sy stert gewaai, gereed vir die avontuur.

Met 'n diep asemteug het Karla die deur oopgestoot. Binne was dit donker en stil. Hulle het stadig deur die kamers geloop en ontdek dat die huis vol ou meubels en speelgoed was. Dit was asof iemand skielik weg is en alles agtergelaat het.

Skielik het Bruno opgewonde begin blaf en na een van die hoeke gehardloop. Daar, onder 'n ou tafel, het Karla 'n skatkis gesien. Haar hart het vinniger begin klop toe sy die kis oopmaak en daarin 'n versameling goue munte en juwele vind.

Karla kon haar oë nie glo nie. Sy het geweet dat hierdie dag een van die mees opwindende avonture in haar lewe sou wees. Sy het besluit om die skat terug huis toe te neem en haar ouers daarvan te vertel.

1.1. Wie is Bruno? (1)

Bruno is die _____.

1.2. Wat het Karla en Bruno een dag besluit om te doen? (1)

- a) Om na die strand te gaan
 b) Om na die ou bos te gaan
 c) Om in die park te speel

1.3. Hoe laat het Karla en Bruno begin stap? (1)

Hulle het _____ gaan stap.

© DesigningMinds

2

VRAAG 4: TAAL IN KONTEKS

4. Antwoord die volgende vrae.

4.1. Onderstreep die byvoeglike naamwoorde in die volgende sinne: (2)

- a) Die verlate huis was vol ou meubels en stowwerige vensters.
 b) Die avontuurlustige meisie het die bos verken."

4.2. Wat is die werkwoord in die volgende sin: (1)

Bruno het opgewonde begin blaf.

opgewonde blaf begin het



4.3. Identifiseer die werkwoord in hierdie sin: (1)

Karla het die deur oopgestoot.

- a) deur
 b) Karla
 c) oopgestoot
 d) het

4.4. Wat is die letterlike betekenis van: (1)

Haar hart het vinniger begin klop?

- a) Sy was moeg.
 b) Sy was bang of opgewonde.

4.5. Wat beteken die skat in die storie? (2)

4.6. Beskryf Karla se persoonlikheid? (1)

avontuurlustig en dapper
 bang
 en onaardig

4.7. Wat beteken die byvoeglike naamwoorde in die volgende sin? (1)

pragtige bome en kleurvolle blomme.

(20)

VRAAG 2: VISUELE TEKS

2.1. Lees die plakkaat en beantwoord die vrae wat volg.

VERLORE HOND



HET JY MICKO GESIEN?

INDIEN WEL, KONTAK ONS
 ASSEBLIEF
 086 748 2920

Micko word seder 14 September vermis, 2024.
 Hy is laas by Summerwood gesien.

Geslag: Reun hond
 Ouderdom: 4 jaar oud
 gewig: 22 kg
 grootte: Medium
 Ons mis hom baie! Hy is vriendelik en goed gemanierd.

R1000
 beloning

© DesigningMinds

4

4.8. Wat beteken die letterlike betekenis van: (1)

~

4.9. Wat is die vlenede vorm: (2)

4.10. Wat is die vrywende vorm: (2)

signingMinds

7

- Begripstoets (20)
- Visuele teks (10)
- Opsomming (5)
- Taal in konteks (15)

Test Total: 50
 Number of pages: 11

Dm

Grade 6 Afrikaans FAL Term 3 Test 2

VRAAG 1: BEGRIPTOETS

1. Lees die volgende teks en beantwoord die vra wat volg.

Die Jakkals en die Blink Klip

Lank gelede, toe diere nog kon praat, het 'n nuuskierige jakkals een middag in die bos gaan stap. Tussen die bome het hy iets blinks op die grond gesien. Hy het nader gestap en gesien dit was 'n gladde, ronde klip — soos 'n spieël!



Toe hy daarin kyk, sien hy 'n gesig. Hy het geglo dit was 'n nuwe dier in die bos. Die jakkals het gegrom en gesê, "Wat maak jy hier?" Die beeld het natuurlik net terug gegrom. Die jakkals het begin grom, geblaas en selfs probeer om die ander dier te jaag.

'n Ou uil het alles van bo af dopgehou en begin lag. "Jakkals," het hy gesê, "dis net jy! Jy sien jou eie gesig in die klip." Die jakkals het rooi in die gesig geraak en stadig weggestap.

Hy het geleer dat dinge nie altyd is soos dit lyk nie, en dat hy eers moet dink voor hy optree.

1.1. Waar het die jakkals die blink klip gekry? (1)

1.2. Wat het die jakkals gedink toe hy in die klip kyk? (2)

1.3. Watter dier het hom vertel wat werklik aan die gang is? (1)

1.4. Hoekom het die jakkals rooi in die gesig geraak en weggestap? (2)

5. Wat beteken die woord "nuuskierig"? (1)

1.6. Kies die korrekte sinoniem vir "geglo": (1)

a) geglimlag

b) gegloei

c) gedink

VRAAG 3: TAALWERK

3. Antwoord die volgende taal vrae:

3.1. Vul die ontbrekende trappe van vergelyking in: (3)

a) mooi		
b) Sterk		
c) slim		

3.2. Skryf die korrekte vorm van die werkwoord in hakies in die regte tyd: (2)

a) Ek _____ (sing) gister 'n lied.

b) Sy _____ (hardloop) vinnig elke dag.



3.3. Is die volgende sinne letterlik of figuurlik? (3)

a) Die wind huil in die nag.

letterlik figuurlik

b) Die son skyn helder vandag.

letterlik figuurlik

c) Hy het 'n hart van goud.

letterlik figuurlik



3.4. Skryf die sin in die taanormestelde vorm: (2)

de vorm)

f. (Lydende vorm)

nde vorm: (2)

watter tipe bywoord dit is (wyse, tyd of plek): (2)

VRAAG 2: KREATIEWE SKRYFWERK

ialoog tussen twee vriende wat gesels oor 'n t plaasgevind het. Die een het opgetree, en die die gehoor gesit.

e 4 reëls per karakter.

orrekte dialoogformaat (naam van karakter, unte, sin) en voeg emosie by jou gesprek.

aestekens korrek.

Ongeveer 80–100 woorde.



Finale teks:

(10)

- Begripstoets (20)
- Kreatiewe Skryfwerk (10)
- Taal in konteks (20)

Test Total: 50
Number of pages: 8

Grade 6 Life Skills PSW Term 3 Test 1

QUESTION 2

2. Read each sentence and say whether it is true or false. Place a cross over the correct box.
- 2.1. Ubuntu means "I am because we are," emphasizing the importance of community and mutual respect. (1)
 True False
- 2.2. In a democracy, the government is chosen by the people through voting. (1)
 True False
- 2.3. The national anthem of South Africa is sung only at sporting events. (1)
 True False
- 2.4. The national flag of South Africa includes the colour blue, which symbolizes peace. (1)
 True False
- 2.5. The Bill of Rights ensures that every citizen has the right to freely express their opinions. (1)
 True False



[5]

QUESTION 3

3. Answer the following questions.
- 3.1. Name TWO places of safety for animals. (2)

- 3.2. Why is it important to care for pets? (1)

- 3.3. Fill in the missing word. (1)
 One aspect of caring for animals is not allowing ignorance or _____ to make you do something cruel to an animal.
- 3.4. Name ONE act of kindness you can show to your friend who is not feeling well. (1)



©DesigningMinds

3

QUESTION 5

5. Read the following case study and answer the questions that follow.

Sam loves playing soccer and is very good at it. She dreams of joining the school's soccer team. However, some of her classmates make fun of her, saying that soccer is a "boys' sport" and that she should play netball instead. This makes Sam feel sad and unsure about whether she should continue playing soccer.



- 5.1. Tick the correct answer. What is gender stereotyping? (1)
- a) The belief that boys and girls can do the same activities.
- b) Assigning roles or activities to individuals based on their gender.
- c) Encouraging everyone to pursue their interests.
- d) Supporting equal opportunities for all genders.
- 5.2. How can gender stereotyping affect someone's confidence and choices? (2)

- 5.3. True or False: Encouraging Lerato to play soccer despite the stereotypes can help break gender norms. (1)
 True False
- 5.4. Tick the correct answer. Which of the following is a form of abuse? (1)
- a) Giving someone a compliment
- b) Ignoring someone's feelings
- c) Physically hurting someone
- d) Helping someone with their homework
- 5.5. True or False: Abuse can only happen between adults. (1)
 True False
- 5.6. Explain why it is important to speak out if you or someone you know is being abused. (2)

©DesigningMinds

6

QUESTION 3

3. Answer the following questions.
- 3.1. Name TWO places of safety for animals. (2)

- 3.2. Why is it important to care for pets? (1)

- 3.3. Fill in the missing word. (1)
 One aspect of caring for animals is not allowing ignorance or _____ to make you do something cruel to an animal.
- 3.4. Name ONE act of kindness you can show to your friend who is not feeling well. (1)



©DesigningMinds

3

- Caring for animals
- Caring for people
- Nation building & cultural heritage
- Gender stereotyping, sexism & abuse

Test Total: 40
 Number of pages: 9

Dm

Grade 6 Geography Term 3 Test 1

QUESTION 2

2. Answer the following questions.

2.1. Have a look at the pictures below and write the letter of the picture underneath the correct heading in the table below. (½ x 6 = 3)



Animals found in a rainforest:	Animals not found in a rainforest:

2.2. Complete the sentences by filling in the most appropriate word about the adaptations of toucans. (4)

Toucans have strong beaks to break open a) _____ and b) _____.

Their _____ are also strong to help them hold onto the branches. Their c)

_____ are small to help them fly between branches and their colours help

them to stay d) _____.

©DesigningMinds

3

d) Can you suggest why the south of the UK is warmer than the north of the UK? (2)

[6]

QUESTION 6

6. Read the text below and answer the questions that follow.

The Amazon Rainforest, located in South America, is one of the most biodiverse regions on Earth. It is home to millions of species of plants, animals, and insects, many of which are found nowhere else. However, in recent decades, the Amazon has been subject to significant deforestation due to human activities such as logging, agriculture, and urbanization.



are very sparsely populated areas. Give TWO reasons for this. (2)

What adaptations do animals that live in desert areas have adapted to living in these harsh climates. Name two adaptations they do to make survival easier. (2)

Why are the fir trees found in coniferous forests triangular in shape? (1)

[12]

What are the effects of climate change on biodiversity? (2)

How does climate change affect the environment? (2)

[4]
GRAND TOTAL: 40 MARKS

35

8

- Climate around the world
- Tropical Rainforests
- Hot deserts
- Coniferous forests

QUESTION 3

3.1. Study the diagram below which shows how relief rainfall is formed, write the correct letter A, B, C or D into the boxes in the diagram. (4)

A – The rising air cools and condenses to form clouds and rain.

B – Warm, moist air from the ocean.

C – The sinking air warms and becomes drier.

D – Warm air is forced to rise over the hills.

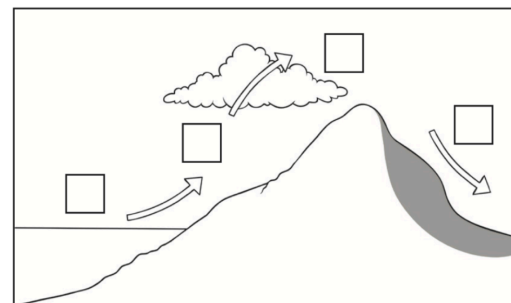

©DesigningMinds

4

Test Total: 40

Number of pages: 10

Dm

Grade 6 Geography Term 3 Test 2

QUESTION 1

1. True or False. Tick the correct box. (1)
- 1.1. The Eastern and Western Hemispheres are the coldest parts of the world. (1)
 True False
- 1.2. The hottest part of the world is along the equator. (1)
 True False
- 1.3. Temperature is affected by the width above sea level. (1)
 True False
- 1.4. The higher a person goes, the colder it gets. (1)
 True False
- 1.5. Places near the sea usually have extremely hot climates. (1)
 True False
- (5)

QUESTION 2

- 2.1. Draw a line from the forest layer to its name. (4)

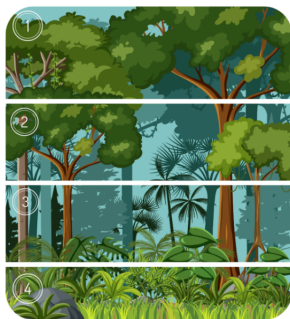

canopy

emergent

forest floor

understory

- 2.2. Which layer gets the most rain and sunlight? (1)

- 2.3. In which layer is it cold and windy? (1)

©DesigningMinds

2

MEMORANDUM GR6 GEOGRAPHY TERM 3 TEST 2

QUESTION	ANSWER	MARKS	LEARNER MARK
QUESTION 1:			
1.1.	False	1	
1.2.	True	1	
1.3.	False	1	
1.4.	True	1	
1.5.	False	1	
		Total: _____/5	

QUESTION 2:

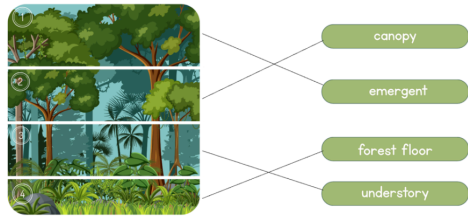
2.1.		4	
2.2.	Canopy	1	
2.3.	Emergent	1	
		Total: _____/8	

layer is dark, hot and humid? (1)

deforestation? (1)

(8)

QUESTION 3

Use the information below and study the picture before answering the questions.

Desert is one of the hottest and driest places on Earth. Temperatures can reach 45°C during the day, but can drop at night. Some plants like cacti and animals like camels, snakes, and scorpions are adapted to survive in the heat. People who live in the desert, like the Bedouins, are called *nomads*.



- 3.1. Say whether these statements are True or False. Tick the correct column. (5)

	True	False
a) Deserts can only be hot all the time.		
b) The Sahara Desert receives very little rainfall.		
c) Some plants are able to grow in deserts.		
d) Camels are well suited to desert life.		
e) People do not live in deserts at all.		

- 3.2. Does a desert get a lot of rainfall? (1)

- 3.3. Name three animals that can live in the desert. (2)

- 3.4. What does the word *nomadic* mean? (1)

©DesigningMinds

3

Number of forests by type	1	
Number of forests by size	1	
Number of forests by location	1	
Number of forests by climate	1	
Number of forests by vegetation	1	
Total: _____/8		

Number of forests by type	5	
Number of forests by size	1	
Number of forests by location	2	
Number of forests by climate	1	
Number of forests by vegetation	1	
Total: _____/10		

6

- Climate around the world
- Tropical Rainforests
- Hot deserts
- Coniferous forests

Test Total: 40

Number of pages: 7



Grade 6 History Term 3 Test I

QUESTION 1

I. Multiple choice. Write the your answer (letter only) in the grid below.

- 1.1. What is democracy? (1)
- A system where one person rules without input from others
 - A system where citizens elect their leaders
 - A system where businesses control the government
 - A system where the military has all the power
- 1.2. South Africa became a democracy in: (1)
- 1990
 - 1991
 - 1994
 - 1995
- 1.3. South African citizens are allowed to start voting at the age of: (1)
- 16
 - 17
 - 18
 - 20
- 1.4. National elections are held every: (1)
- 4 years
 - 5 years
 - 6 years
 - 7 years
- 1.5. South Africa's first democratically elected leader was: (1)
- Julius Malema
 - Nelson Mandela
 - Thabo Mbeki
 - Oliver Tambo
- 1.6. What is the Constitutional Court responsible for? (1)
- Making laws
 - Checking that laws follow the Constitution
 - Running elections
 - Managing schools



I.1.	I.2.	I.3.	I.4.	I.5.	I.6.
------	------	------	------	------	------

[6]

©DesigningMinds

2

QUESTION 2

Source below and answer the questions that follow.

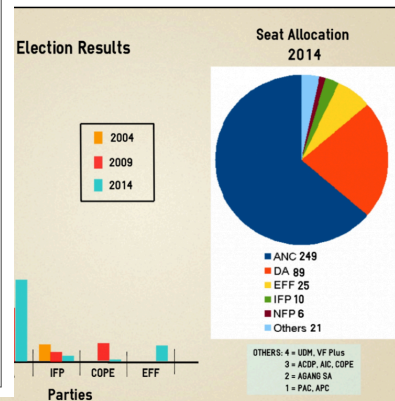

<https://www.pa.org.za/blog/infographic-election-results-and-allocation-seats->

- 2.1. Which political party has won all 3 elections? (1)
-
- 2.2. Which political party has grown the most over the course of the last three elections according to the table? (1)
-
- 2.3. What is the difference between the number of seats that the ANC and the NFP has, according to the pie graph? Show your calculation. (1)
-
- 2.4. Voting is essential to democracy because it gives citizens the power to shape their country's future, hold their leaders accountable, and ensure that their voices are heard.
- Write a letter to your older cousin who is thinking about not voting in the next election. In your letter explain why they should go and vote. Use the template below. (5)

©DesigningMinds

3

MEMORANDUM GR6 HISTORY TERM 3 TEST

QUESTION	ANSWER	MARKS	LEARNER'S MARK
QUESTION 1			
I.1.	b) A system where citizens elect their leaders	1	
I.2.	c) 1994	1	
I.3.	c) 18	1	
I.4.	a) 4 years	1	
I.5.	b) Nelson Mandela	1	
I.6.	b) Checking that laws follow the Constitution	1	
		Total: ____/5	

QUESTION 2

2.1.	ANC	1	
2.2.	DA	1	
2.3.	$249 - 6 = 243$ seats	1	
2.4.	Any relevant answers	5	
		<ul style="list-style-type: none"> Significance of voting Voting is one of the most powerful tools we have as a citizen to shape the future of our country and make our voices heard. It is our responsibility. 	
		Total: ____/8	

te

Total: ____/8

	1	
	1	
	1	
	1	
		Total: ____/4

ixes and obeying the law	2	
rotect people's rights.	2	
of people with shared ideas who	2	
vern the country. They give citizens		

©DesigningMinds

8

• Democracy & citizenship

Test Total: 40

Number of pages: 9



Grade 6 History Term 3 Test 2

QUESTION 1

1. Choose the correct answer. Write only the letter (a–d) in the grid below.

- 1.1. What is the role of the government? (1)
 a) To entertain the public
 b) To create and enforce the country's laws
 c) To sing the national anthem
 d) To vote for citizens
- 1.2. Why do we have a Constitution? (1)
 a) To guide how the country is governed
 b) To decide which party wins
 c) To make people follow leaders blindly
 d) To change the national anthem
- 1.3. What is a national anthem? (1)
 a) A law book
 b) A group of politicians
 c) A country's flag
 d) A song to show respect to a country
- 1.4. Which one is a responsibility? (1)
 a) Voting in elections
 b) Obeying the law
 c) Watching the news
 d) Having free time
- 1.5. Which sentence describes a right? (1)
 a) Being allowed to break rules
 b) Having to attend school daily
 c) Being allowed to express your opinion
 d) Following your parents' orders

1.1.	1.2.	1.3.	1.4.	1.5.
------	------	------	------	------

(5)



©DesigningMinds

2

5.6. What is South Africa's national animal? (1)

5.7. What is South Africa's national anthem called? (1)

5.8. What flower is in the picture below? (1)



(10)

QUESTION 6

6.1. Say what colour each part of the flag is. (6)

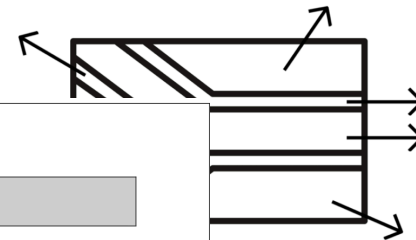

QUESTION 4

Each sentence is True or False.

1. The South African constitution promises freedom and equality for all citizens. (1)
2. Members of parliament are chosen through a lucky draw. (1)
3. A democratic government allows people to vote for their leaders. (1)
4. The African National Congress (ANC) government in South Africa was elected in 2004. (1)
5. People have the right to choose who will represent them. (1)

(5)

QUESTION 5

5. Answer the following questions:

5.1. What is the Constitutional Court? (2)

5.2. What is the job of parliament? (1)

5.3. What is the highest office in the land and who currently holds that position? (2)

5.4. What is South Africa's national bird? (1)

5.5. What is South Africa's national fish? (1)

©DesigningMinds

5

(6)
 GRAND TOTAL: 40

©DesigningMinds

6

- Democracy & citizenship:
- Voting, role of parliament, constitution, rules & laws, justice system, childrens rights & responsibilities, national symbols

Test Total: 40
 Number of pages: 8

Dm

Grade 6 Mathematics Term 3 Test I

1.6. What is the area of the carpet if the tiles are 1 square meter each? (1)



- a) 28 square meters
- b) 22 square meters
- c) 15 square meters
- d) 16 square meters

1.7. What is the perimeter of the following rectangle, if the measurements are as indicated? (1)



- a) 15m
- b) 30m
- c) 50m
- d) 100m

1.8. What type of angle is shown below? (1)

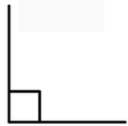

- a) An acute angle
- b) An obtuse angle
- c) A reflex angle
- d) A right angle

©DesigningMinds

(8)

3

b)

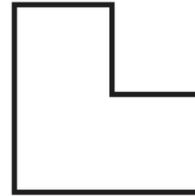

3.4. Find the area of the shape below. (3)

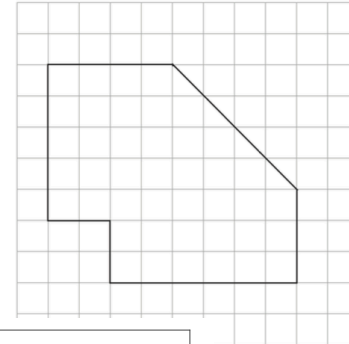

QUESTION 2: PROPERTIES OF 2D SHAPES

Complete the table by filling in the missing information. (9)

Picture	Number of sides	Name of angles
	4 sides	
	7 sides	Obtuse angles
Pentagon		Obtuse

(2)

15

7

2.2. For each of the pairs of shapes given below, give one way they are the same and one way they are different. (4)

a)

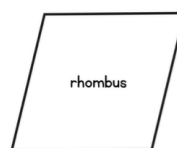

rhombus

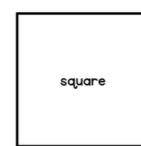

square

.....

.....

©DesigningMinds

4

- Properties of 2D Shapes
- Symmetry & Transformation
- Properties of 3D objects
- Area, perimeter & Volume

Test Total: 50

Number of pages: 13



Grade 6 Mathematics Term 3 Test 2

3.5. Find the area of the shape below. (3)

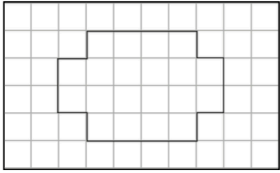

Area: _____

3.6. Find the volume of the shape below. (2)

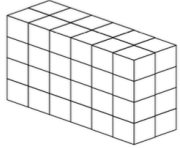

(14)

QUESTION 4: TRANSFORMATIONS & SYMMETRY

4.1. Complete the pattern and use the translations to help you.

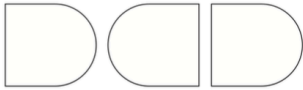

4.2. Describe the patterns below using transformations (translations, rotations, reflections)

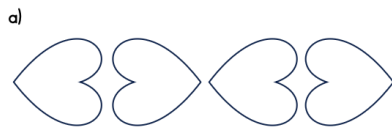

©DesigningMinds

5.3. Which prize was won the most? (1)

5.4. How many different prizes are available in the claw machine? (1)

(11)

QUESTION 6: 3D SHAPES

6.1. Name the 3D shapes below. (2)

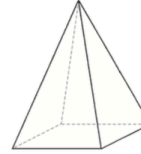

a) _____

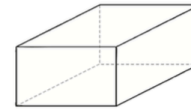

b) _____

6.2. Complete the table below. (4)

3D object	Number of faces	Number of vertices	Number of edges	Flat or curved or both

(6)
GRAND TOTAL: 50

©DesigningMinds

8

QUESTION 1: M

1. Answer the multiple choice questions or

1.1. Say what view you are looking at the chair

- a) Top
b) Front
c) Right
d) Left



1.2. Look at the pattern below and say which

98 84 70 56

- a) 40
b) 42 (56-14 = 42)
c) 43
d) 44

1.3. Have a look at the pattern below and say



- a) Add one more match to the previous pattern to get the next pattern.
b) Add two more match to the previous pattern to get to the next pattern.
c) Add three more matches to the previous pattern to get the next pattern.
d) Add four more matches to the previous pattern to get the next pattern.

1.4. Which of the following is the mode in the data set: 7, 8, 8, 9, 10, 11? (1)

- a) 7
b) 8
c) 10
d) 11

1.5. Estimate the mass of a school bag filled with books. (1)

- a) 500 g
b) 5 kg
c) 50 kg
d) 5000 kg



1.1.	1.2.	1.3.	1.4.	1.5.
------	------	------	------	------

(5)

©DesigningMinds

2

- Fractions & decimals
- Measurement (Area, perimeter & volume)
- Transformations & Symmetry
- Data handling
- 3D shapes

Test Total: 50

Number of pages: 12

Dm

Grade 6 Natural Science & Technology Term 3 Test I

QUESTION 1: CHOOSE THE CORRECT WORD IN BRACKETS

1. Choose the correct word in brackets.
- 1.1. An electric circuit is a (closed / open) loop through which an electric current can flow.
- 1.2. Electrical conductors allow electricity to (flow / stop) through them easily.
- 1.3. Insulators do not allow electricity to (flow / stop) through them easily.
- 1.4. Fossil fuels are burned to generate (renewable / non-renewable) energy.
- 1.5. Renewable energy sources such as wind and solar power are (renewable / non-renewable) and do not run out.



[5]

QUESTION 2: COLUMN MATCH

2. Match the term in column A to their correct descriptions in column B. Write your answer (letter a-e) in column C.

Term	Description	Answer
2.1. Electric Circuit	a) A material that allows electricity to flow through it easily.	
2.2. Conductor	b) A closed loop through which an electric current can flow.	
2.3. Insulator	c) A material that does not allow electricity to flow through it easily.	
2.4. Fossil Fuels	d) Energy sources that can be replenished naturally, such as wind, sunlight, and water.	
2.5. Renewable Energy	e) Fuels such as coal, oil, and natural gas that were formed from the remains of ancient plants and animals.	

[5]

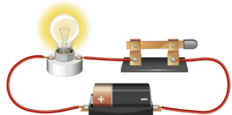

©DesigningMinds

MEMORANDUM GR6 NST TERM 3 TEST

QUESTION	ANSWER	MARKS	LEARNER MARK
QUESTION 1: CHOOSE THE CORRECT WORD IN BRACKETS			
1.1.	Closed	1	
1.2.	Flow	1	
1.3.	Flow	1	
1.4.	Non-renewable	1	
1.5.	Renewable	1	
		Total: ____/5	
QUESTION 2: COLUMN MATCH			
2.1.	b) A closed loop through which an electric current can flow.	1	
2.2.	a) A material that allows electricity to flow through it easily.	1	
2.3.	c) A material that does not allow electricity to flow through it easily.	1	
2.4.	e) Fuels such as coal, oil, and natural gas that were formed from the remains of ancient plants and animals.	1	
2.5.	d) Energy sources that can be replenished naturally, such as wind, sunlight, and water.	1	
		Total: ____/5	
QUESTION 3: ELECTRIC CIRCUITS			
3.1	resistor switch	6	

QUESTION 3: ELECTRIC CIRCUITS

- 3.1. Draw a simple circuit that includes a battery, a switch, and a light bulb. (1)
- 3.2. Name the four main parts of the circuit: battery, switch, wire, light bulb, and resistor. (5)



complete, so electric
ed circuit is a complete
ough it.

- 3.2. Explain what an open circuit is and how it differs from a closed circuit. (2)

- 3.3. Draw a circuit that shows an open switch. (2)

[10]

- Electrical circuits
- Electrical conductors & insulators
- Systems to solve problems
- Mains electricity

Test Total: 30
Number of pages: 7

Grade 6 Natural Science & Technology Term 3 Test 2

QUESTION 1

1. Have a look at the simple circuit below and fill in the missing labels. (5)

Light bulb, battery, resistor, wire, switch

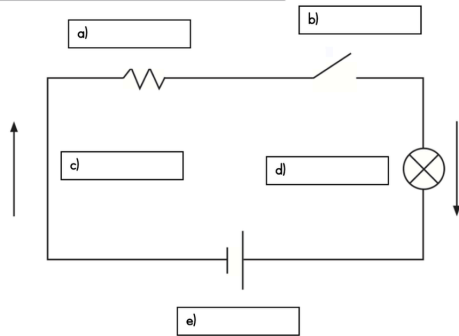

(5)

QUESTION 2

2. Answer the following:

2.1. Explain what an open circuit is and how it differs from a closed circuit. (2)

.....

2.2. Draw a circuit that shows an open switch. (2)

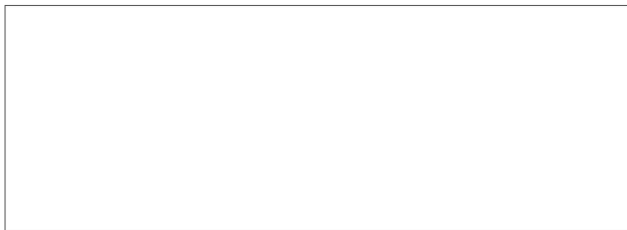

(4)

QUESTION 3

of the following materials are conductors or insulators: ($\frac{1}{2} \times 6 = 3$)

Conductor or Insulator



d) Metal



e) Rubber



f) Wood



3.2. Define a what a conductor is and what an insulator is and give an example of each. (4)

.....

(7)

QUESTION 5

5. Read the text and answer the questions that follow.

Lebo's family recently decided to save electricity at home. They replaced their old light bulbs with energy-saving LED bulbs. They also bought a new fridge and washing machine that use less power. During the day, they keep the curtains open to let in sunlight instead of turning on lights. At night, they switch off all appliances that are not in use, like the TV and phone chargers. Lebo even made signs to remind everyone to turn off lights when leaving a room!



5.1. List three appliances in Lebo's home that are eco-friendly. (1)

.....

5.2. Give two ways Lebo's family conserves energy at home. (2)

.....

5.3. Why do you think Lebo made signs to remind the family to switch off lights? (1)

.....

..... save electricity at home? Explain your answer. (2)

.....

.....

(6)
TOTAL MARKS: 30



- Electrical circuits
- Electrical conductors & insulators
- Systems to solve problems
- Mains electricity

Test Total: 30

Number of pages: 8